

MANIFOLD FOR ADDITIONAL SINGLE ACTING CIRCUIT

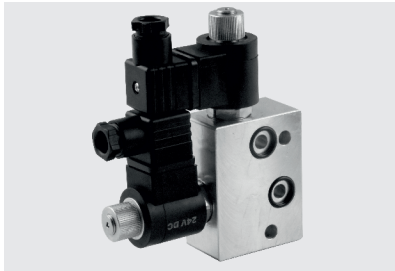

Dimensions in mm (inches)
Typically used to create a single acting circuit in parallel with a double acting circuit

Main features

Max pressure	350 bar
Weight	0,39 Kg (0,88lb)
Fixing bolts	2 M8 tie - rods steel class 8.8 or above

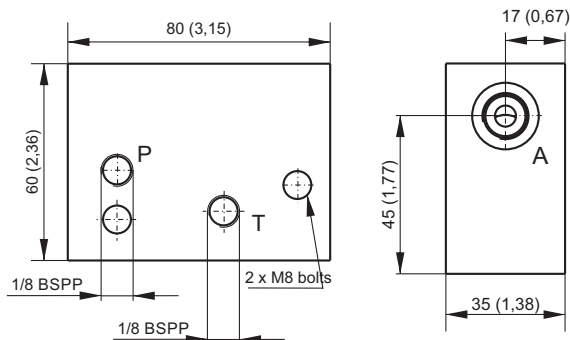

Spare part code
E60403039
E60403039US*

ASSEMBLY CODE - example

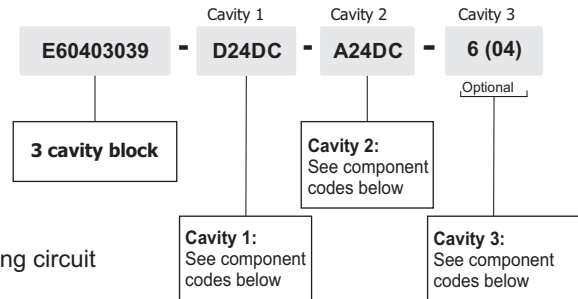

Application example

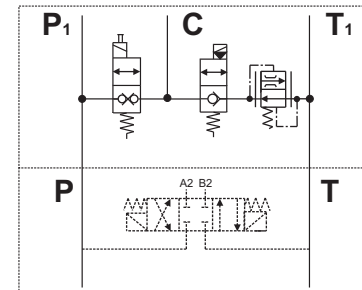

S		CSB	
Z		CPE	
D		MDV30E	
C		MSV31E	
A		MSV30	
B		MSV30E	
T		CSPC15	
L		E70100004	
N		E70100002	

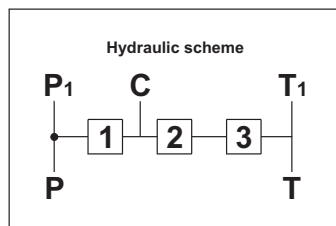
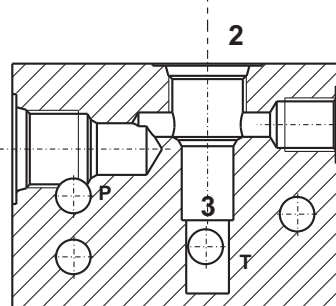

	CSB		S
	CPE		Z
	MDV30E		D
	MSV31E		C
	MSV30		A
	MSV30E		B
	CSPC15		T
	E70100005		G
	E70100006		P
	E70100003		H
	VSC04		*

Note: to add external manifolds to PPC assembly code, just add their spare part codes at the end of the PPC code.
Example: PPC-0,8 12DC-UA-J-G1,1-V200-G-RETURN KIT-G-1,5L+E60403039-D24DC-A24DC-6(04).
The valve attachment is on the motor side. With AC motor frames bigger than 71 and DC motors bigger than dia. 125, always add a spacer manifold (see E60403004 code in F section) below the modular block to avoid interference between the valve and the motor.
Recommended tightening torque for M8 bolts: 16 Nm. Attention! Do not use tie-rods less than 8.8.