

Return Filters

E 103 · E 143

Tank top mounting · Connection up to G1 / -16 SAE · Nominal flow rate up to 135 l/min / 35.7 gpm



Return Filter E 103

Description

Application

In the return line circuits of hydraulic systems.

Performance features

Protection against wear:

By means of filter elements that even in full-flow filtration meet the highest demands regarding cleanliness classes.

Protection against malfunction:

By means of full-flow filtration in the system return, the pumps above all are protected from dirt particles remaining in the system after assembly, repairs, or which are generated by wear or enter the system from outside.

Special features

- › By-pass valve:
The location close to the inlet port prevents dirt particles retained by the filter element from entering into the clean oil side.
- › Removable bowl:
In case of maintenance the filter bowl is removed together with the filter element - therefore dirt particles are not flushed back into the tank.
- › AirEX air separation
Prevents impairments and damage caused by air in the hydraulic medium and enables a significant reduction in tank size.
- › Extension pipe:
A correct extension pipe length ensures oil outlet below minimum oil level and prevents foaming.

Filter elements

Flow direction from outside to center.

The star-shaped pleating of the filter material results in:

- › large filter surfaces
- › low pressure drop
- › high dirt-holding capacities
- › long service life

Ventilating Filter

Ventilation of the reservoir by an integral star-shape pleated filter element:

- › removable (replace annually!)
- › splash-proof
- › fineness 2 µm

Materials

Screw-on cap:	Polyamide, GF-reinforced
Filter head:	Aluminum alloy
Filter bowl:	Polyamide, CF-reinforced, electrically conducting
Seals:	NBR (FPM on request)
Filter media:	EXAPOR®MAX 3 - inorganic multi-layer microfiber web

Filter maintenance

By using a clogging indicator the correct moment for maintenance is stated and guarantees the optimum utilization of the filter life.

Accessories

Electrical and optical clogging indicators are available on request. Dimensions and technical data see catalog sheet 60.20.

For versions with ventilation filter, an oil separator is available to prevent oil being ejected during mobile operation (order no.: E 043.1701).

Extension pipes on the bowl outlet are available in several lengths on request.

Characteristics

Nominal flow rate

Up to 135 l/min / 35.7 gpm (see Selection Chart, column 2). The nominal flow rates indicated by ARGO-HYTOS are based on the following features:

- › closed by-pass valve at $v \leq 200 \text{ mm}^2/\text{s}$ / 927 SUS
- › element service life > 1000 operating hours at an average fluid contamination of 0.07 g per l/min / 0.27 g per gpm flow volume
- › flow velocity in the connection lines $\leq 4.5 \text{ m/s}$ / 14.8 ft/s

Connection

Threaded ports according to

- › ISO 228 or DIN 13
- › SAE standard J514

Sizes see Selection Chart, column 6, (other port threads on request).

For installation recommendations, see info sheet 00.325.

Filter fineness

5 $\mu\text{m(c)}$... 16 $\mu\text{m(c)}$

β -values according to ISO 16889

(see Selection Chart, column 4 and diagram Dx).

Dirt-holding capacity

Values in g test dust ISO MTD according to ISO 16889 (see Selection Chart, column 5).

Hydraulic fluids

Mineral oil and biodegradable fluids (HEES and HETG, see info-sheet 00.20).

With high filling conditions we recommend an electrical conductivity $\geq 500 \text{ pS/m}$ at 20 °C / 68 °F.

Temperature range

-30 °C ... +100 °C (temporary -40 °C ... +120 °C)

-22 °F ... +212 °F (temporary -40 °F ... +248 °F)

Viscosity at nominal flow rate

- › at operating temperature: $v < 60 \text{ mm}^2/\text{s}$ / 280 SUS

- › as starting viscosity: $v_{\text{max}} = 1200 \text{ mm}^2/\text{s}$ / 5560 SUS

- › at initial operation:

The recommended starting viscosity can be read from the diagram D (pressure drop as a function of the kinematic viscosity) as follows: Find the 70% Δp of the cracking pressure of the by-pass valve on the vertical axis. Draw a horizontal line so that it intersects the Δp curve at a point. Read this point on the horizontal axis for the viscosity.

Operating pressure

Max. 10 bar / 145 psi

Mounting position

Preferably vertical, outlet downwards.

Δp-curves for complete filters in Selection Charts, column 3

D1 Pressure drop as a function of the **flow volume** at $v = 35 \text{ mm}^2/\text{s} / 162 \text{ SUS}$ (0 = casing empty)

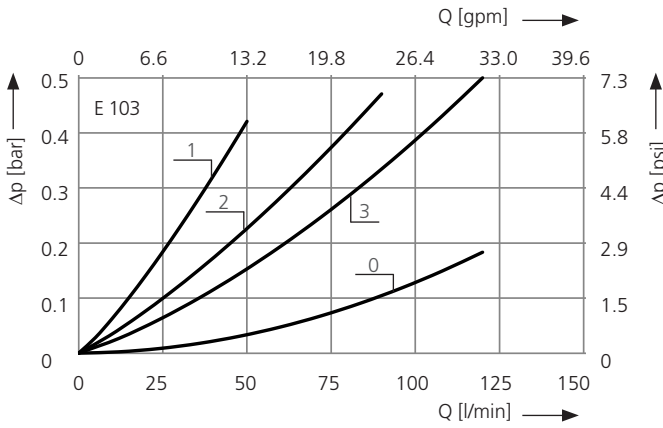

Pressure drop as a function of the **kinematic viscosity** at nominal flow

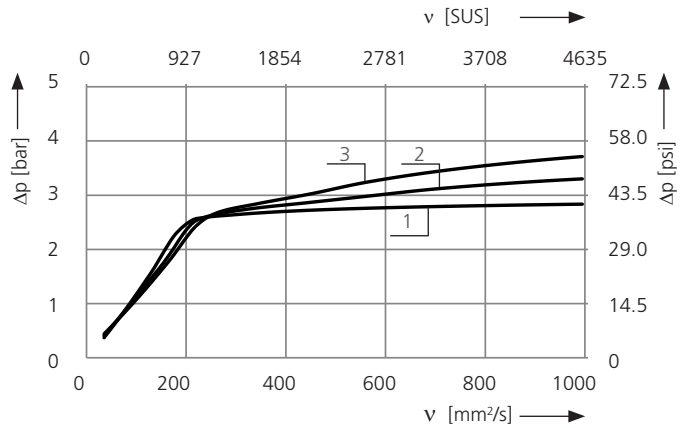

D2 Pressure drop as a function of the **flow volume** at $v = 35 \text{ mm}^2/\text{s} / 162 \text{ SUS}$ (0 = casing empty)

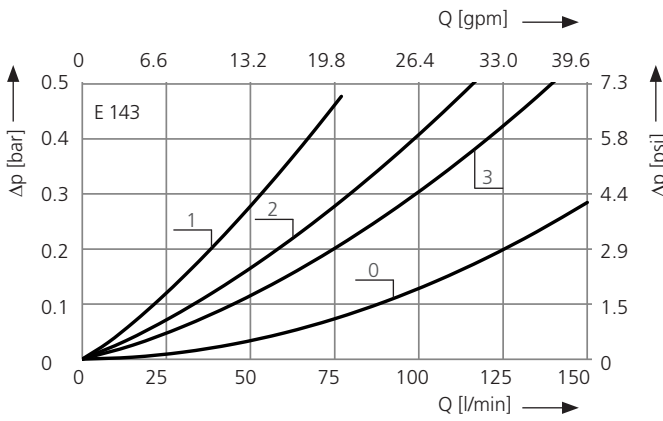

Pressure drop as a function of the **kinematic viscosity** at nominal flow

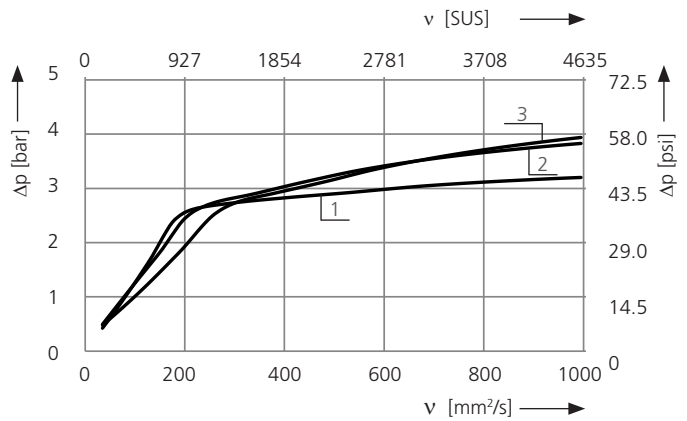

Filter fineness curves in Selection Chart, column 4

Dx Filtration ratio β as a function of particle size x obtained by the Multi-Pass-Test according to ISO 16889

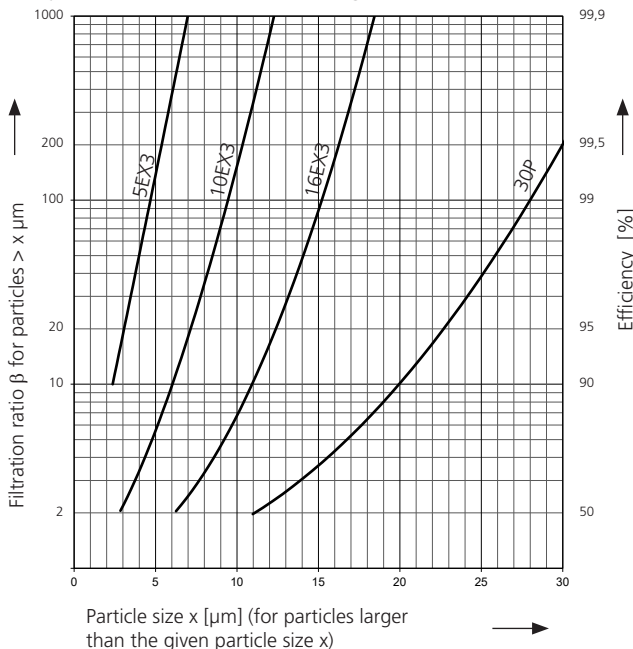

The abbreviations represent the following β -values resp. finenesses:

For EXAPOR®MAX 3 and Paper elements:

5EX3 = $\beta_{5(c)} = 200$	EXAPOR®MAX 3
10EX3 = $\beta_{10(c)} = 200$	EXAPOR®MAX 3
16EX3 = $\beta_{16(c)} = 200$	EXAPOR®MAX 3
30P = $\beta_{30(c)} = 200$	Paper

Based on the structure of the filter media of the 30P paper elements, deviations from the printed curves are quite probable.

For screen elements:

40S = screen material with mesh size	40 μm
60S = screen material with mesh size	60 μm
100S = screen material with mesh size	100 μm

Tolerances for mesh size according to DIN 4189

For ventilating filter elements:

2 CL = 99.5 % efficiency for particles of size 2 μm

For special applications, finenesses differing from these curves are also available by using special composed filter media.

Selection Chart

Part No.	Nominal flow rate	Pressure drop see diagram D /curve no.	Filter fineness	Dirt-holding capacity	Connection A	Cracking pressure of by-pass	Symbol	Replacement element Part No.	Weight	Replacement ventilating filter Part No. (Filter fineness, see diagrams)	Remarks
	l/min		g	bar				kg			
1	2	3	4	5	6	7	8	9	10	11	12
E 103-657	45	D1/1	5EX3	28	G $\frac{3}{4}$	2.5	2	V3.0620-53	1.0	L1.0503-03 (2CL)	-
E 103-677	45	D1/1	5EX3	28	G $\frac{3}{4}$	2.5	1	V3.0620-53	1.0	-	-
E 103-676¹	80	D1/2	10EX3	27	G $\frac{3}{4}$	2.5	2	V3.0620-56	1.0	L1.0503-03 (2CL)	-
E 103-686¹	80	D1/2	10EX3	27	G $\frac{3}{4}$	2.5	1	V3.0620-56	1.0	-	-
E 103-898¹	110	D1/3	16EX3	27	G1	2.5	2	V3.0620-58	1.0	L1.0503-03 (2CL)	-
E 103-888¹	110	D1/3	16EX3	27	G1	2.5	1	V3.0620-58	1.0	-	-
E 143-657	70	D2/1	5EX3	39	G $\frac{3}{4}$	2.5	2	V3.0730-53	1.2	L1.0503-03 (2CL)	-
E 143-667	70	D2/1	5EX3	39	G $\frac{3}{4}$	2.5	1	V3.0730-53	1.2	-	-
E 143-676¹	115	D2/2	10EX3	42	G1	2.5	2	V3.0730-56	1.2	L1.0503-03 (2CL)	-
E 143-686¹	115	D2/2	10EX3	42	G1	2.5	1	V3.0730-56	1.2	-	-
E 143-888¹	135	D2/3	16EX3	42	G1	2.5	2	V3.0730-58	1.2	L1.0503-03 (2CL)	-
E 143-688¹	135	D2/3	16EX3	42	G1	2.5	1	V3.0730-58	1.2	-	-

¹ Preferred type, no minimum order quantity required

All filters are delivered with a plugged clogging indicator connection M12 x 1.5. As clogging indicators either manometers or electrical pressure switches can be used. Optional extension pipes adapt the filter length to various tank depths. For ordering of accessories please use the below mentioned codes.

Order example: The filter E 103-676 is to be supplied with air separation and an extension pipe for a mounting depth of 500 mm.

Order description: E 103-676 / AE / EV 500

Part No. (Basic unit) _____

Housing outlet ²: _____

2 different versions are available

AE - Air separation AirEX, EV - extension pipe

Mounted extension pipe (7 various lengths are available on request) _____

E 103: EV 196, EV 256, EV 300, EV 350, EV 400, EV 500, EV 600

E 143: EV 297, EV 357, EV 400, EV 450, EV 500, EV 600, EV 700

For the suitable clogging indicators please see catalog sheet 60.20.

Remarks:

- › The switching pressure of the electrical pressure switch has always to be lower than the cracking pressure of the by-pass valve (see Selection Chart, column 7).
- › Clogging indicators are optional and always delivered detached from the filter.
- › The filters listed in this chart are standard filters. Other designs available on request.

² on request, the air separation can be combined with an extension pipe

Selection Chart

Part No.	Nominal flow rate	Pressure drop see diagram D /curve no.	Filter fineness	Dirt-holding capacity	Connection A	Cracking pressure of by-pass	Symbol	Replacement element Part No.	Weight	Replacement ventilating filter Part No. (Filter fineness, see diagrams)	Remarks
1	gpm	3	g	SAE	psi	8	9	lbs	11	12	
E 103-763	11.9	D1/1	5EX3	28	-16 ²	36	2	V3.0620-53	2.2	L1.0503-03 (2CL)	inkl. Ölabscheider
E 103-753	11.9	D1/1	5EX3	28	16 ²	36	1	V3.0620-53	2.2	-	-
E 103-777¹	21.1	D1/2	10EX3	27	16 ²	36	2	V3.0620-56	2.2	L1.0503-03 (2CL)	inkl. Ölabscheider
E 103-756¹	21.1	D1/2	10EX3	27	16 ²	36	1	V3.0620-56	2.2	-	-
E 103-798¹	29.1	D1/3	16EX3	27	16 ²	36	2	V3.0620-58	2.2	L1.0503-03 (2CL)	inkl. Ölabscheider
E 103-788¹	29.1	D1/3	16EX3	27	16 ²	36	1	V3.0620-58	2.2	-	-
E 143-763	18.5	D2/1	5EX3	39	16 ²	36	2	V3.0730-53	2.7	L1.0503-03 (2CL)	inkl. Ölabscheider
E 143-753	18.5	D2/1	5EX3	39	16 ²	36	1	V3.0730-53	2.7	-	-
E 143-776¹	30.4	D2/2	10EX3	42	16 ²	36	2	V3.0730-56	2.7	L1.0503-03 (2CL)	inkl. Ölabscheider
E 143-786¹	30.4	D2/2	10EX3	42	16 ²	36	1	V3.0730-56	2.7	-	-
E 143-788¹	35.7	D2/3	16EX3	42	16 ²	36	2	V3.0730-58	2.7	L1.0503-03 (2CL)	inkl. Ölabscheider
E 143-798¹	35.7	D2/3	16EX3	42	16 ²	36	1	V3.0730-58	2.7	-	-

¹ Preferred type, no minimum order quantity required

² Corresponds to 1⁵/₁₆ -12 UN-2B

All filters are delivered with a plugged clogging indicator connection M12 x 1.5. As clogging indicators either manometers or electrical pressure switches can be used. Optional extension pipes adapt the filter length to various tank depths. For ordering of accessories please use the below mentioned codes.

Order example: The filter E 103-763 is to be supplied with air separation and an extension pipe for a mounting depth of 500 mm (19.69 inch).

Order description: E 103-763 / AE / EV 500

Part No. (Basic unit)

Housing outlet ²:

2 different versions are available

AE - Air separation AirEX, EV - extension pipe

Mounted extension pipe (7 various lengths are available on request)

E 103: EV 196 (7.71 inch). EV 256 (10.08 inch). EV 300 (11.81 inch). EV 350 (13.78 inch). EV 400 (15.74 inch). EV 500 (19.69 inch). EV 600 (23.62 inch)

E 143: EV 297 (11.69 inch). EV 357 (14.06 inch). EV 400 (15.74 inch). EV 450 (17.71 inch). EV 500 (19.69 inch). EV 600 (23.62 inch). EV 700 (27.56 inch)

For the suitable clogging indicators please see catalog sheet 60.20.

Remarks:

- › The switching pressure of the electrical pressure switch has always to be lower than the cracking pressure of the by-pass valve (see Selection Chart, column 7).
- › Clogging indicators are optional and always delivered detached from the filter.
- › The filters listed in this chart are standard filters. Other designs available on request.

³ on request, the air separation can be combined with an extension pipe

Dimensions

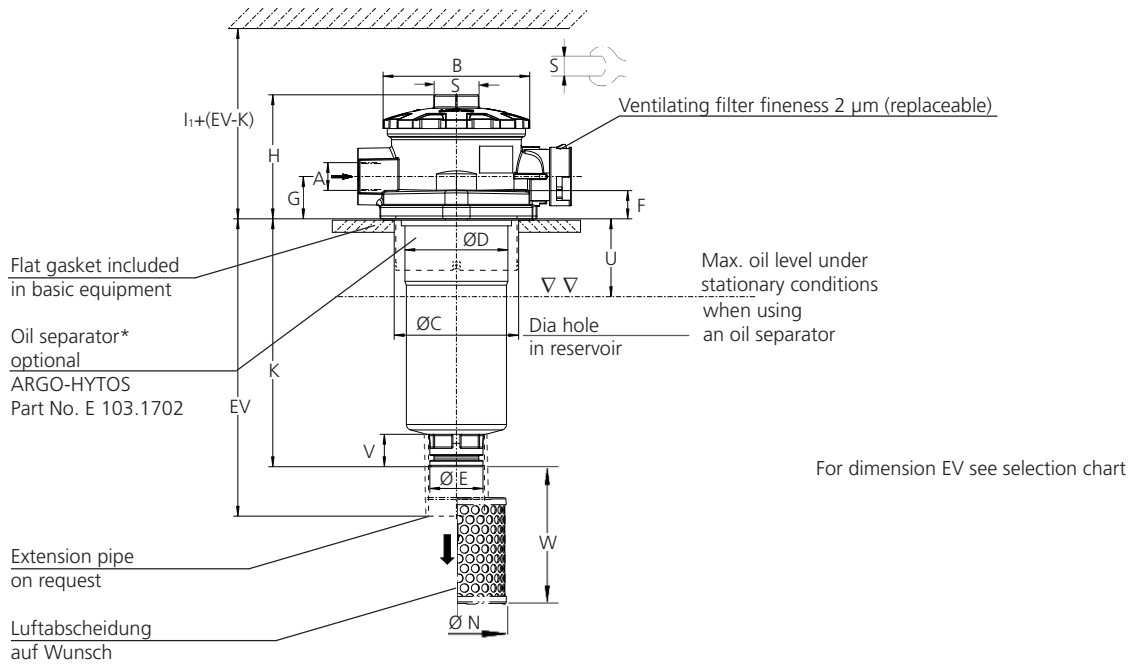

Design without ventilating filter

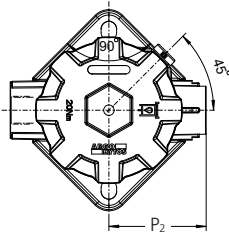

Design with ventilating filter

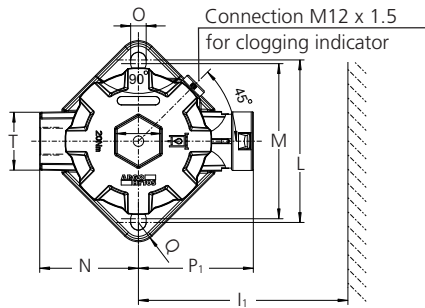

Required mounting surface

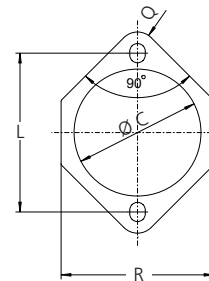

* Included in the scope of delivery for versions with SAE-16 (connection A)

Measurements in mm

Type	A	B	C min./max.	D	E	F	G	H	I ₁	I ₂	K	L	M	N	O
E 103	G ³ / ₄ , G1	105	87/91	73.5	38	20.5	30	88.5	300	125	177	115	110	70	11
E 143	G ³ / ₄ , G1	105	87/91	73.5	38	20.5	30	88.5	400	125	278	115	110	70	11

Type	P ₁	P ₂	Q	R	S	T	U	V	W						
E 103	82	69	13.5	107.5	AF 32	AF 41	50	23	90						
E 143	82	69	13.5	107.5	AF 32	AF 41	50	23	90						

Measurements in inch

Type	A SAE	B	C min./max.	D	E	F	G	H	I ₁	I ₂	K	L	M	N	O
E 103	-16**	4.13	3.43/3.58	2.9	1.5	0.81	1.18	3.48	11.81	4.92	6.97	4.53	4.33	2.76	0.43
E 143	-16**	4.13	3.43/3.58	2.9	1.5	0.81	1.18	3.48	15.75	4.92	10.94	4.53	4.33	2.76	0.43

Type	P ₁	P ₂	Q	R	S mm	T mm	U	V	W						
E 103	3.23	2.72	0.53	4.23	AF 32	AF 41	1.97	0.91	3.54						
E 143	3.23	2.72	0.53	4.23	AF 32	AF 41	1.97	0.91	3.54						

** Corresponds to 1¹/₁₆-12 UN-2B

Symbols

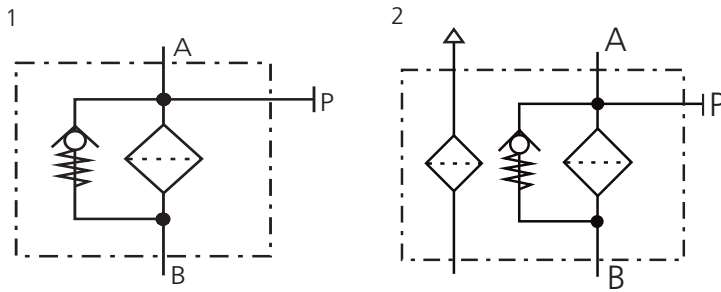

Spare Parts

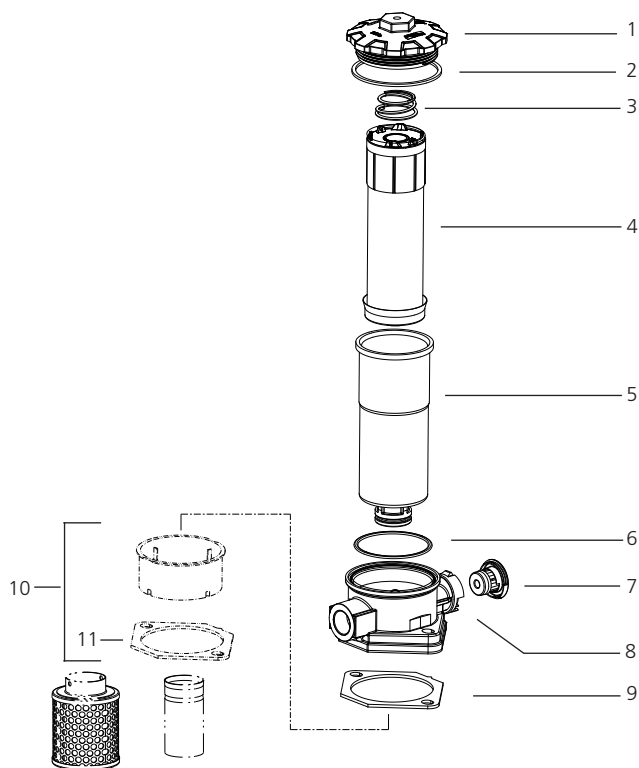

Pos.	Designation	Part No.
1	Screw-on cap	E 103.0201
2	Flat gasket	N031.0841
3	Compression spring	N015.3703
4	Replacement filter element	see Chart / col. 9
5	Filter bowl E103*	E 103.0912
5	Filter bowl E143*	E 143.0903
6	O-ring 69.5 x 3.5 mm 2.74 x 0.14 inch	N007.0703
7	Replacement ventilating filter	L1.0503-03K
8	Housing (for pos. 7)	L1.0503.0801
9	Flat gasket (for versions without oil separator)	E 103.0147
10	Oil separator (incl. pos. 11)	E 103.1702
11	Flat gasket (for versions with oil separator)	E 103.0148

*Specify mounting depth (EV) in mm

The functions of the complete filters as well as the outstanding features of the filter elements assured by ARGO-HYTOS can only be guaranteed if original ARGO-HYTOS spare parts are used.

Quality Assurance

Quality management according to DIN EN ISO 9001

To ensure constant quality in production and operation, ARGO-HYTOS filter elements undergo strict controls and tests according to the following ISO standards:

- ISO 2941 Verification of collapse / burst pressure rating
- ISO 2942 Verification of fabrication integrity (Bubble Point Test)
- ISO 2943 Verification of material compatibility with fluids
- ISO 3968 Evaluation of pressure drop versus flow characteristics
- ISO 16889 Multi-Pass-Test (evaluation of filter fineness and dirt-holding capacity)
- ISO 23181 Determination of resistance to flow fatigue using high viscosity fluid

Various quality controls during the production process guarantee the leakfree function and solidity of our filters.

Illustrations may sometimes differ from the original. ARGO-HYTOS is not responsible for any unintentional mistake in this specification sheet.