

Return Filters

D 090 · D 100

In-line mounting · Connection G $\frac{3}{4}$ / -12 SAE · Nominal flow rate up to 110 l/min / 29.1 gpm



In-line Return Filter D 090

Description

Application

In the return line circuits of hydraulic systems.

Performance features

Protection against wear:

By means of filter elements that even in full-flow filtration meet the highest demands regarding cleanliness classes.

Protection against malfunction:

By means of full-flow filtration in the system return, the pumps above all are protected from dirt particles remaining in the system after assembly, repairs, or which are generated by wear or enter the system from outside.

Filter elements

Flow direction from outside to center.

The star-shaped pleating of the filter material results in:

- › large filter surfaces
- › low pressure drop
- › high dirt-holding capacities
- › long service life

Filter maintenance

By using a clogging indicator the correct moment for maintenance is stated and guarantees the optimum utilization of the filter life.

Materials

Filter head: Aluminum alloy
 Filter bowl: Polyamide, GF reinforced
 Seals: NBR (FPM on request)
 Filter media: EXAPOR[®]MAX 3 - inorganic multi-layer microfiber web
 Paper - cellulose web, impregnated with resin

Accessories

Electrical and / or optical clogging indicators are available on request. Dimensions and technical data see catalog sheet 60.20.

Nominal flow rate

Up to 110 l/min / 29.1 gpm (see Selection Chart, column 2)
The nominal flow rates indicated by ARGO-HYTOS are based on the following features:

- › closed by-pass valve at $v \leq 200 \text{ mm}^2/\text{s}$ / 927 SUS
- › element service life > 1000 operating hours at an average fluid contamination of 0.07 g per l/min / 0.27 g per gpm flow volume
- › flow velocity in the connection lines $\leq 4,5 \text{ m/s}$ / 14.8 ft/s

Connection

Threaded ports according to

- › ISO 228 or DIN 13
- › SAE standard J514

Sizes see Selection Chart, column 6,
(other port threads on request).

For installation recommendations, see info sheet 00.325.

Filter fineness

10 $\mu\text{m(c)}$... 16 $\mu\text{m(c)}$

β -values according to ISO 16889

(see Selection Chart, column 4 and diagram Dx).

Dirt-holding capacity

Values in g test dust ISO MTD according to ISO 16889
(see Selection Chart, column 5).

Hydraulic fluids

Mineral oil and biodegradable fluids
(HEES and HETG, see info-sheet 00.20).

Temperature range

-30 °C ... +100 °C (temporary -40 °C ... +120 °C)

-22 °F ... +212 °F (temporary -40 °F ... +248 °F)

Viscosity at nominal flow rate

- › at operating temperature: $v < 60 \text{ mm}^2/\text{s}$ / 280 SUS
- › as starting viscosity: $v_{\text{max}} = 1200 \text{ mm}^2/\text{s}$ / 5560 SUS
- › at initial operation:

The recommended starting viscosity can be read from the diagram D (pressure drop as a function of the kinematic viscosity) as follows: Find the 70% Δp of the cracking pressure of the by-pass valve on the vertical axis. Draw a horizontal line so that it intersects the Δp curve at a point. Read this point on the horizontal axis for the viscosity.

Operating pressure

Max. 10 bar / 145 psi

Mounting position

Preferably vertical, filter head on top.

Δp-curves for complete filters in Selection Chart, column 3

D1 Pressure drop as a function of the **flow volume** at $v = 35 \text{ mm}^2/\text{s} / 162 \text{ SUS}$ (0 = casing empty)

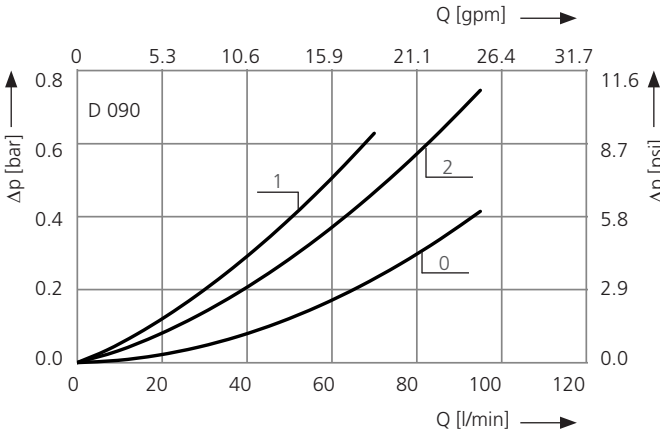

Pressure drop as a function of the **kinematic viscosity** at nominal flow

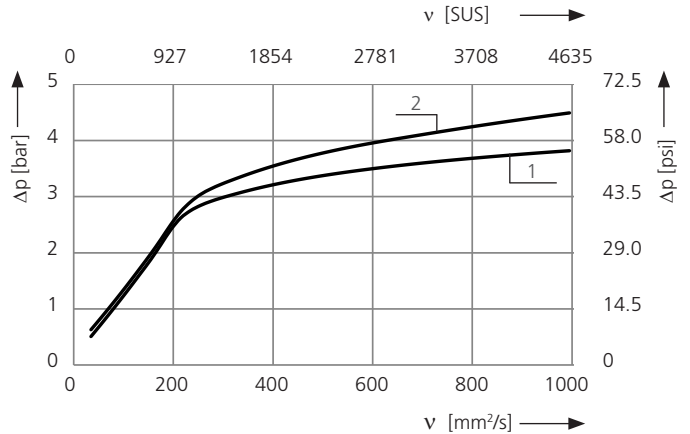

D2 Pressure drop as a function of the **flow volume** at $v = 35 \text{ mm}^2/\text{s} / 162 \text{ SUS}$ (0 = casing empty)

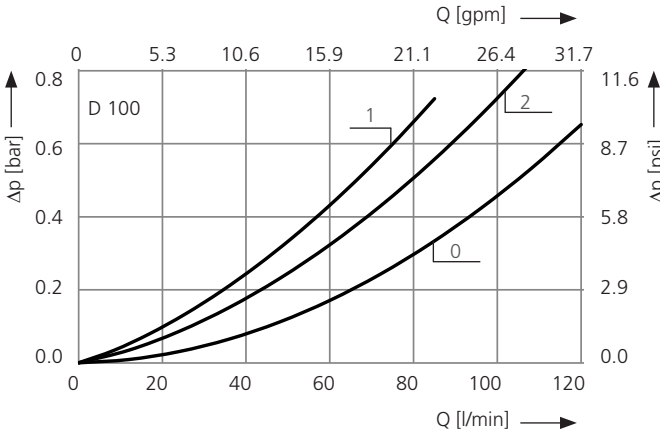

Pressure drop as a function of the **kinematic viscosity** at nominal flow

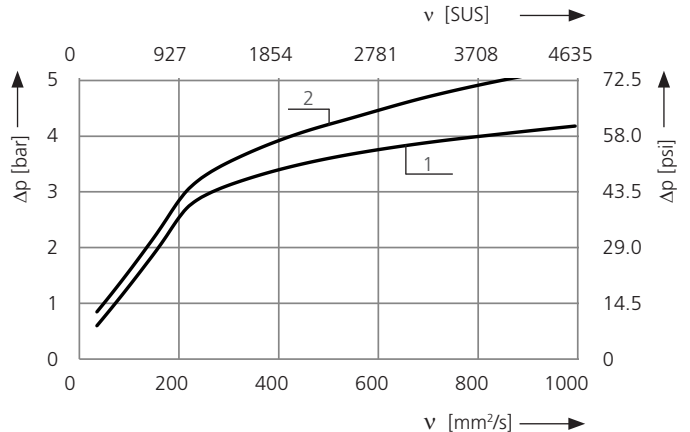

Filter fineness curves in Selection Chart, column 4

Dx Filtration ratio β as a function of particle size x obtained by the Multi-Pass-Test according to ISO 16889

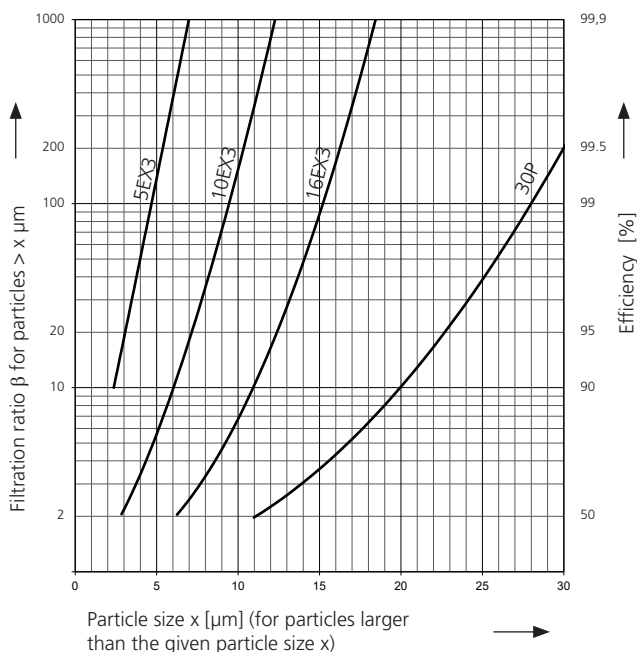

The abbreviations represent the following β -values resp. finenesses:

For EXAPOR®MAX 3 and Paper elements:

- 5EX3 = $\beta_{5(c)} = 200$ EXAPOR®MAX 3
- 10EX3 = $\beta_{10(c)} = 200$ EXAPOR®MAX 3
- 16EX3 = $\beta_{16(c)} = 200$ EXAPOR®MAX 3
- 30P = $\beta_{30(c)} = 200$ Paper

Based on the structure of the filter media of the 30P paper elements, deviations from the printed curves are quite probable.

For screen elements:

- 40S = screen material with mesh size 40 μm
- 60S = screen material with mesh size 60 μm
- 100S = screen material with mesh size 100 μm

Tolerances for mesh size according to DIN 4189

For special applications, finenesses differing from these curves are also available by using special composed filter media.

Selection Chart

Part No.	Nominal flow rate	Pressure drop see diagram	Filter fineness see Diagr. Dx	Dirt-holding capacity	Connection A/B	Cracking pressure of by-pass	Symbol	Replacement element Part No.	Weight	Remarks
	l/min			g		bar			kg	
1	2	3	4	5	6	7	8	9	10	11
D 090-156	60	D1/1	10EX3	19	G $\frac{3}{4}$	2,5	2	V3.0714-06	0.9	-
D 090-158	85	D1/2	16EX3	20	G $\frac{3}{4}$	2,5	2	V3.0714-08	0.9	-
D 100-156	75	D2/1	10EX3	24	G $\frac{3}{4}$	2,5	2	V3.0717-06	1.0	-
D 100-158	110	D2/2	16EX3	26	G $\frac{3}{4}$	2,5	2	V3.0717-08	1.0	-

	gpm			g	SAE	psi			lbs	
1	2	3	4	5	6	7	8	9	10	11
D 090-756	15.9	D1/1	10EX3	19	-12*	36	2	V3.0714-06	1.98	-
D 090-758	22.5	D1/2	16EX3	20	-12*	36	2	V3.0714-08	1.98	-
D 100-756	19.8	D2/1	10EX3	24	-12*	36	2	V3.0717-06	2.20	-
D 100-758	29.1	D2/2	16EX3	26	-12*	36	2	V3.0717-08	2.20	-

* Corresponds to 1 $\frac{1}{16}$ -12 UN-2B

All filters are delivered with a plugged clogging indicator connection M12 x 1.5.
As clogging indicators either manometers or electrical pressure switches can be used.

For the appropriate clogging indicator please see catalog sheet 60.20.

Remarks:

- › The indicating pressure of the pressure gauge or the switching pressure of the electrical pressure switch has always to be lower than the cracking pressure of the by-pass valve (see Selection Chart, column 7).
- › Clogging indicators are optional and always delivered detached from the filter.
- › The filters listed in this chart are standard filters. Other designs available on request.

Dimensions

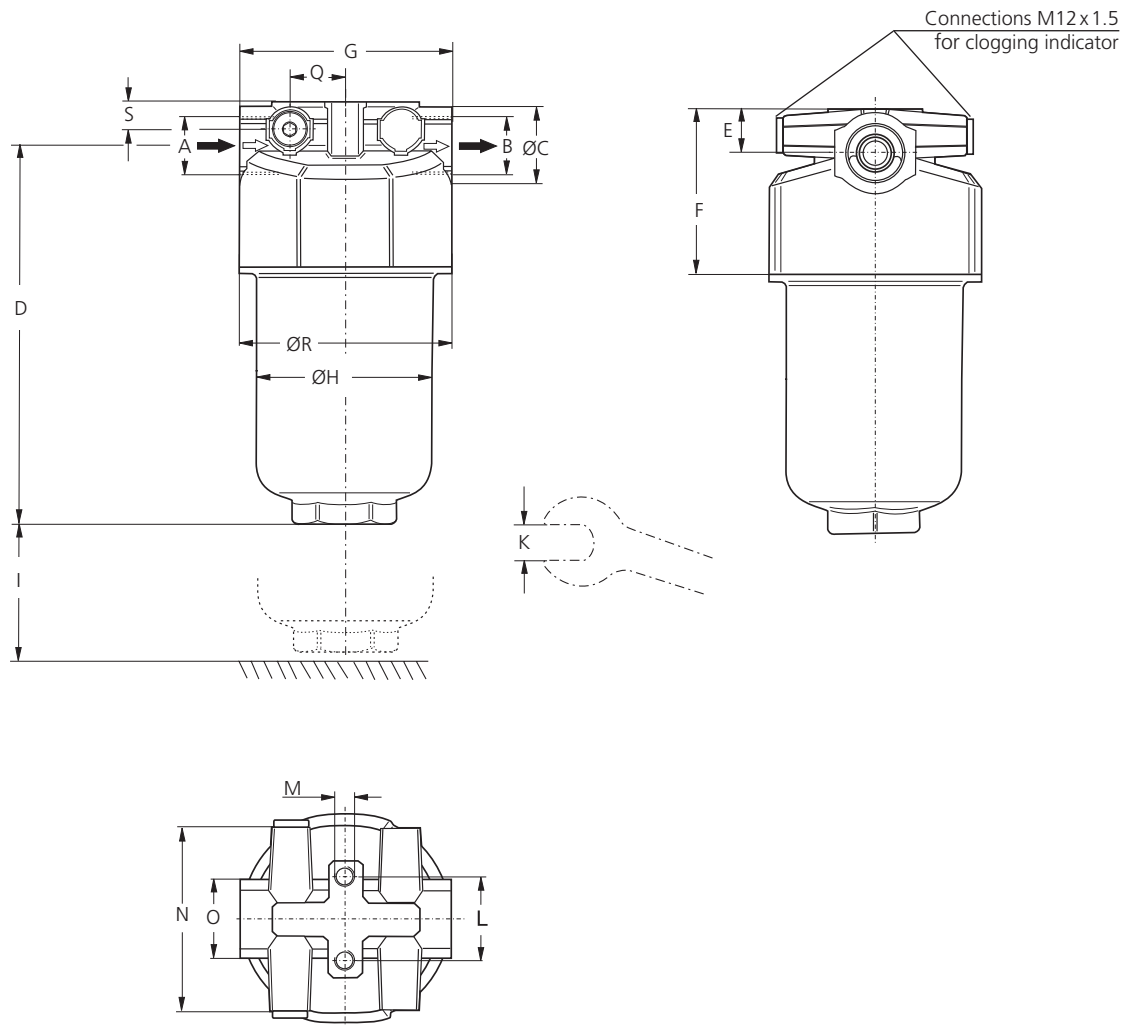

Measurements in mm

Type	A	B	C	D	E	F	G	H	I	K	L	M Ø / depth	N	O	Q	R	S
D 090	G $\frac{3}{4}$	G $\frac{3}{4}$	35	178	20	74	95	80	70	AF 41	38.1	M8 / 15	82	AF 36	25	95	12
D 100	G $\frac{3}{4}$	G $\frac{3}{4}$	35	212	20	74	95	80	70	AF 41	38.1	M8 / 15	82	AF 36	25	95	12

Measurements in inch

Type	A SAE	B SAE	C	D	E	F	G	H	I	K mm	L	M Ø / depth	N	O mm	Q	R	S
D 090	-12*	-12*	1.38	7.01	0.79	2.91	3.74	3.15	2.76	AF 41	1.50	M8 / 15	3.23	AF 36	0.98	3.74	0.47
D 100	-12*	-12*	1.38	8.35	0.79	2.91	3.74	3.15	2.76	AF 41	1.50	M8 / 15	3.23	AF 36	0.98	3.74	0.47

* Corresponds to 1 $\frac{1}{16}$ -12 UN-2B

Symbols

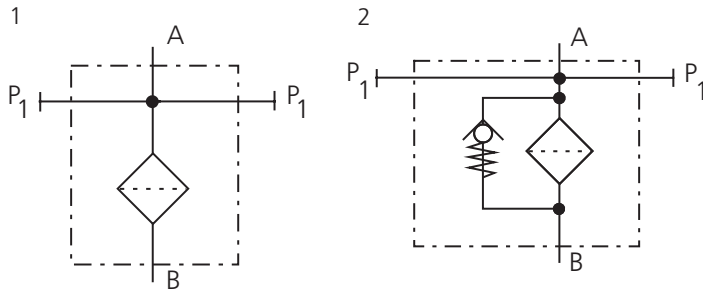

Spare Parts

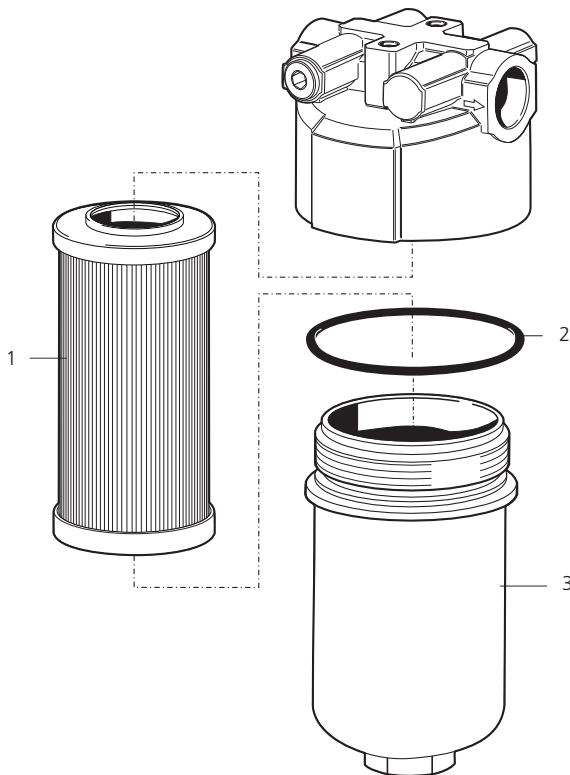

Pos.	Designation	Part No.
1	Replacement filter element	see Chart / col. 9
2	O-ring 82.14 x 3.53 mm 3.23 x 0.14 inch	N007.0824
3	Filter bowl D 090	E 068.0101
3	Filter bowl D 100	E 068.0102

The functions of the complete filters as well as the outstanding features of the filter elements assured by ARGO-HYTOS can only be guaranteed if original ARGO-HYTOS spare parts are used.

Quality Assurance

Quality management according to DIN EN ISO 9001

To ensure constant quality in production and operation, ARGO-HYTOS filter elements undergo strict controls and tests according to the following ISO standards:

- ISO 2941 Verification of collapse / burst pressure rating
- ISO 2942 Verification of fabrication integrity (Bubble Point Test)
- ISO 2943 Verification of material compatibility with fluids
- ISO 3968 Evaluation of pressure drop versus flow characteristics
- ISO 16889 Multi-Pass-Test (evaluation of filter fineness and dirt-holding capacity)
- ISO 23181 Determination of resistance to flow fatigue using high viscosity fluid

Various quality controls during the production process guarantee the leakfree function and solidity of our filters.

Illustrations may sometimes differ from the original. ARGO-HYTOS is not responsible for any unintentional mistake in this specification sheet.